

WONCHANG

**Installation
and
Operating Manual**

**PCX Series Compressor
Model PCX 255, 305, 405 & 515**

www.wonchangvacuum.com

July. 2020 REV1

INSTALLATION & OPERATING MANUAL

PCX-SERIES CLAW COMPRESSOR

PCX 255, 305, 405 & 515

Please read the manual before operating the compressor.

TABLE OF CONTENTS

1.0 INSTALLATION

- 1.1 General description
- 1.2 Unpacking
- 1.3 Location
- 1.4 Power Requirements
- 1.5 Pressure Connections
- 1.6 Oil Filling on Gear box

2.0 SAFETY

- 2.1 General Notices
- 2.2 Warning Label and explanation
- 2.3 Location of Labels

3.0 OPERATION

- 3.1 Start-up
- 3.2 Stopping the compressor
- 3.3 Ambient operating conditions & limits

4.0 MAINTENANCE

- 4.1 Compressor Gear Lube Oil (level / type & quantity / change)
- 4.2 Inline (inlet) Filter
- 4.3 Maintenance Chart

5.0 PROBLEM SOLVING

6.0 TECHNICAL DATA

7.0 TYPICAL PCX-SERIES ASSEMBLY DRAWING AND PARTS LIST

INSTALLATION AND OPERATING MANUAL

This manual is written to cover following contact-less operating claw Compressors. The model number is stamped into the nameplate with serial number: PCX 255, 305, 405 & 515

Please identify the model number and serial number when ordering parts.

1.0 INSTALLATION

1.1 General description

The PCX Compressor is dry and contactless machines, enclosed in acoustic sound shield and designed to have cooling air passed through the sound shield by fan. The warm air is exhausted through the vent. The PCX is constructed in modular construction consisting of two compartments: pumping and gear chambers separated by using labyrinth seals. In the pump chamber, as two rotary claws rotate in opposite direction, the air sucked in, shall be compressed and discharged under pressure. In the gear chamber (box), two gears for synchronizing of claws rotation will be located with oil lubrication. For reduction of the noise, inlet silencer shall be installed in compressor inlet side. For a protection of overload, a pressure safety valve or regulating valve is installed in exhaust. The compressors are directly driven by a flanged motor via a coupling. The PCX Series compressors are identical in internal construction to VCX vacuum pump, but are outfitted with different inlet and outlet accessories to allow for operation as a compressor.

1.2 Unpacking

Inspect the box and compressor carefully for any signs of damage incurred in transit. Since all compressors are ordinarily shipped F. O. B. from our factory or regional warehouse, such damage is the normal responsibility of the carrier and should be reported to them.

The compressor is bolted to the skid with studs that are connected through the rubber feet of compressor. Remove the nuts from the underside of the crate and remove the compressor. Unscrew the studs from the rubber feet.

The inlet and exhaust of the compressor are covered with plastic caps to prevent dirt and other foreign substances from entering compressor. Leave these caps in place until you are ready to pipe the compressor to your equipment.

1.3 Location

Install the compressor in a horizontal position on a level surface so that the pump can be evenly supported on its rubber feet. Leave 30 ~ 45 cm of access around the compressor to allow proper cooling. Also, adequate ventilation must be provided for the cooling,

Allow access to the oil sight glass in order to inspect the oil level regularly, and the oil fill and oil drain port for easy service.

1.4 Power Requirements

A schematic diagram for the electrical motor terminal connections is located in the junction box of the motor or on the motor nameplate. Typical wirings for Three Phase Motors are as below:

Wiring Scheme- Three Phase Motor

Low Voltage

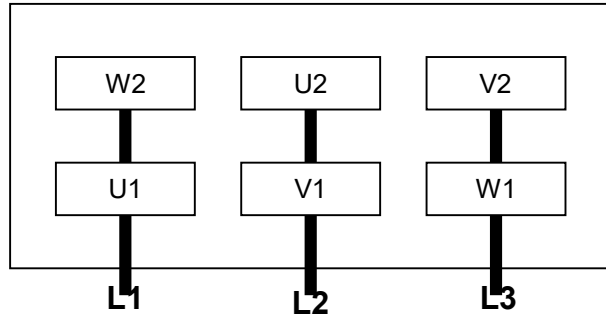
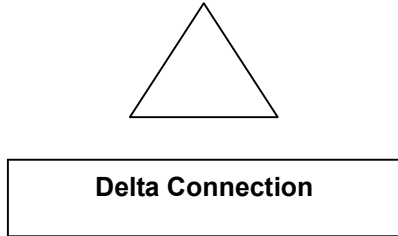

High Voltage

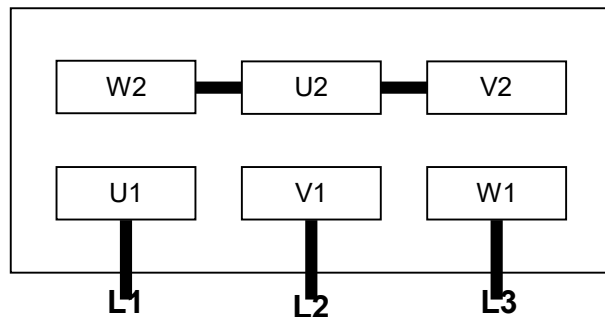
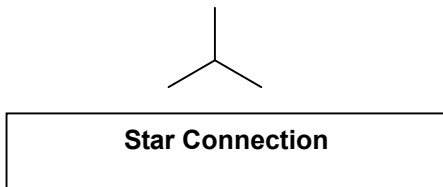

The motor must be connected according to the electrical codes through a fused switch in order to protect the motor against electrical or mechanical overload conditions. The overload of the motor starter must be set at a level equal to the full load motor current listed on the motor nameplate.

If the compressor is supplied with a motor starter, it is preset at the factory according to customer specifications. It is advisable to check that these settings are in line with the voltage at your location. If the voltage is different, please contact Wonchang for motor and starter information.

Correct direction of rotation is marked by an arrow on the motor fan housing and is counterclockwise when looking at the motor from the motor's fan side.

After electrical connections have been made, the rotation of the motor should be checked. If backward, reverse any two leads of the three at the power connection.

1. 1.5 Pressure Connections

Use a pipe size that is at least the size of the compressor inlet connections. Smaller lines result in a reduced compressor capacity.

Compressors operating in parallel on a common main line should have a manual or automatic operated shut-off valve or positive action check valve, installed in the suction line adjacent to the pump suction flange. Remove the plastic protective cap from the discharge port prior to connection of compressor to the system.

Should process gas contain dust or other foreign particles, a suitable in line (inlet) filter should be connected to the inlet port. Consult Wonchang for recommendations.

The following thread sizes are standard on the compressors (NPT thread is available upon request)

<u>Model</u>	<u>Inlet Size</u>	<u>Exhaust Size</u>
PCX 255 & 305	G 2"	G 2"
PCX 405 & 515	G 3"	G 3"

@ Inlet Silencer @Exhaust Connection Housing

1.6 Oil Filling on Gear Box

The pump is shipped without oil in gear box. After level installation and correct rotation has been established, fill the pump with recommended gear oil through the oil fill port. Oil level should be over 3/4 position on the oil sight glass as shown on the label.



We recommend ISO VG150 gear oil or equivalent oils.

- **Shell OMALA HD 150 or Amsoil GEAR LUBE 150 or ANDEROL # 4150**

The following table gives the approximate quantities of oil required for each model.

<u>Pump Model</u>	<u>Capacity (liter)</u>
VCX 255 & 305	0.90
VCX 405 & 515	1.80

Do not add fill oil with pump running! Do not overfill.

2.0 SAFETY

Please read the following safety notice carefully before operating the compressor.

2.1 General Notices

- Understand fully this installation and operating manual before operation.
- The other person except authorized operator should not operate the pump
- When the pump is not properly working, it should be stopped immediately.
- Wonchang shall have no liability for any accident and failure arising from no compliance with instructions in this manual.

2.2 Warning labels and its explanation

Following warning labels are shown and attached on PCX series compressors.

2.2.1 Read and Understand a manual:

Read and understand operator's manual before using this machine

2.2.2 Burn Hazard:

Hot surface. Do not touch.

2.2.3 Loud noise Hazard

Loud noise hazard. Ear protection must be worn.

2.2.4 Hazardous Voltage:

Disconnect power before opening. Contact causes severe electrical shock



2.3 Location of the labels

The labels of 2.2.1 Read and Understand a manual, 2.2.2 Burn Hazard, and 2.2.3 Loud noise Hazard shall be shown on the top of sound shield of compressor.

The label of 2.2.4 Hazardous Voltage shall be shown on the cover of motor's terminal box

3.0 OPERATION

3.1 Start-up

Check rotation of the motor as described in paragraph 1.4 Power Requirements.

Fill the compressor with oil as described in paragraph 1.5 - Oil Filling

Start the compressor with the inlet closed. Run the compressors for a few minutes and then shut down. Check the oil level again and make sure the oil level is 1/2 position of oil sight glass.

Add oil though oil fill port, if necessary. Pump oil should only be added when the pump is off

3.2 Stopping the compressor

To stop the compressor, turn off the power.

3.3 Operating Conditions and limits

The PCX Series are designed to run below set pressures according to the motor power for continuous operation. Operation over maximum pressure level may result in failure of and severe damage to the machine. Pressure Regulator installed in outlet flange is set at maximum allowable pressure (see the table for set of pressure) at factory.

Caution: Any non compliance may lead to severe injury to persons and damage to the compressor.

The pressure can be adjusted by turning the stud of pressure regulating valve on the top of valve. The regulating valve or safety valve is set at permissible operating pressure and will be opened to discharge the pressure if the compressor runs over the setting pressure for a safety operation.

Caution: Do not run the compressor without regulating valve or safety valve. Do not set the regulating valve or safety valve at over permissible pressure. The compressor may be damaged severely.

The standard version is for use of dry air only, and may not be used in hazardous areas. Handling of humid air or gases containing aggressive chemicals is possible only with specially configured units. Consult Wonchang for assistance.

Also it is recommended for operating personnel who is working near the compressor to wear ear protectors. If noise below the designed dBA is required, an external sound enclosure can be added to the system, provided adequate ventilation is provided

The ambient and suction air temperature must be between 5 and 40 °C deg

Caution: Any non compliance may lead to severe injury to persons and damage to the compressor

4.0 MAINTENANCE

PCX Series Compressors require very little maintenance. To ensure optimum performance, the following maintenance steps should be followed:

4.1 Compressor Lube Oil

4.1.1 Gear Oil Level

Check the oil level on monthly basis. Under normal circumstances it should not be necessary to add oil between oil changes. A significant drop in oil level means there is an oil leak. Please check the o-rings, drain plug or oil sight glass.

Check the oil level only when the compressor is shut off. Replenish oil if it drops below bottom position of the sight glass.

Caution: Do not add oil while the compressor is running, since hot oil can escape from the oil fill port.

4.1.2 Gear Oil Type and Quantity

See section 1.5 - Oil Filling - for details on oil type and quantity

4.1.3 Oil Change

Under normal ambient conditions with proper Gear Oil, it is recommended to change the oil every 10,000 operating hours. It is necessary to make the first oil change between 500 ~1000 operating hours..

Caution: *If different brand oil is being filled, the old oil must be drained completely from the gear box.*

Caution: *Above interval of lubrication is based on ambient temperature of 20 °C. At 40 °C ambient temperature operation, it may be shorten to half.*

4.2 Inline (Inlet) Filter

Check inline (inlet) filter on a weekly basis. The filter cartridge should be cleaned or replaced when dirty. Consult service agent for replacement element information.

Caution: *Depending on the mounting position of the filter, be careful not to allow accumulated foreign material to fall in the pump suction inlet when removing the filter cartridge. Horizontal filter installation is recommended to prevent this.*

4.3 Maintenance Chart

Weekly: Check inline inlet filter element. More often if high particulates in inlet stream

Monthly: Check the oil level, Protective Mesh.

Semi-Annually: Check cooling fan and coupling

Annually: Check Bearings/ Shaft Seals, More frequently if operated at ambient temperature exceeding 20°C

Every 5000 operating hours: Check the gear oil conditions, and if necessary, change the oils.



Inspection hole with G1" plug: Check the coupling and its insert, and fan through this hole regularly. (The endoscope(WireCam) can be used with Smart Phone software)

5.0 PROBLEM SOLVING

5.1 Problem

Compressor does not reach capacity.

5.1.1 Possible Cause

Inlet screen (mesh) of the inlet filter clogged with debris.

Remedy : check inlet filter element and clean screen (mesh) by compressed air or wash it.

5.1.2 Possible Cause

Pipe work is too long or small.

Remedy : Use the bigger diameter pipe and shorten the lines length if possible.

5.2 Problem

Compressor runs over set pressure.

5.2.1 Possible Cause

Pressure Regulator or Safety Valve set over the set point, or is out of order.

Remedy : Set the point again or replace it with new one.

5.3 Problem

Compressor does not reach the set pressure.

5.3.1 Possible Cause

Leak on the compressor or system.

Remedy : Check the leak on the compressor or system.

5.4 Problem

Compressor runs very noisy.

5.4.1 Possible cause

Contamination of the claws.

Remedy : Clean the pumping chamber and rotary claws.

5.4.2 Possible cause

Coupling insert is worn.

Remedy : replace coupling insert in motor/pump coupling.

5.4.3 Possible Cause

Bearing noise

Remedy : replace bearings or call service agent for service or exchange program.

5.5 Problem

Compressor will not start.

5.5.1 Possible Cause

Supply voltage is not proper or is overloaded. Motor starter overload settings are too low or improper; fuses are burned; wire size is too small or too long causing a voltage drop.

Remedy : check voltage supply; overload settings in motor starter for size and settings according to motor nameplate. Install proper size wire. If ambient temperature is high, use the next larger size overloads or adjust settings 5% above motor nameplate value.

Remedy : turn compressor fan by hand. If it will not turn, remove motor from Compressor and check motor and compressor separately. Repair or replace if needed or call service agent for service or exchange program.

5.6 Problem

Compressor is running too hot.

5.6.1 Possible Cause

Not enough air ventilation to Compressor

Remedy : Make certain a sufficient amount of fresh air is supplied to the Compressor.

Dirty or Blocked Mesh

Remedy : Check the flow of cooling air and clean the metal mesh of any debris blocking the air as necessary.

5.6 Problem

Compressor will not operate (seized up).

5.7.1 Possible cause

Rotary Claws, Bearings or Gears stuck on..

Remedy : Call service agent for service or exchange program

6.0 TECHNICAL DATA

Model		PCX 255				PCX 305			PCX 405				PCX 515			
M3/ Hour	60Hz	300				360			480				600			
	50Hz	250				300			400				500			
Press. Conti., Bar	60Hz	0.8	1.4	1.7	2.2	1	1.8	2.2	0.6	1.2	1.6	2	0.8	-	1.6	2
	50Hz	1	~	2	~	0.6	1.4	2.2	0.8	1.4	1.8	2	0.8	1.2	1.6	2
Kw	60Hz	9.2	11	15	15	11	15	18.5	15	18.5	22	30	18.5	-	30	37
	50Hz	7.5	~	11	~	7.5	11	15	11	15	18.5	22	15	18.5	22	30
RPM - 60/50Hz	RPM	3450 / 2850														
Voltage, Available	V	208~230/460V, 220~240 / 380~420V, 400/690V														
dB(A), Ave	60Hz	82				82			82				83			
	50Hz	80				79			81				81			
Oil Capa (Gear box)	Ltr	0.9						1.8								
Inlet / Outlet Conn.	**BSP(G)	2"						3"								
W x H (mm)		573 x 757				573 x 757			672 x 1003				672 x 1003			
L* (mm)	60Hz	1001	1171	1171	1171	~	1183	1183	1274	1274	1340	1395	1289	~	1410	1410
	50Hz	961	~	1171	~	973	1183	1183	1274	1274	1274	1340	1289	1289	1355	1410
Amb. Operating Temp	(°C)	5°C ~40°C														
Accessories		Pressure Regulator, Safety Valve, Inlet Silencer, and Inlet Filter														

Note: 1) * Length varies to motor mfg 2) **NPT threads available upon request

Note: Ultimate Continuous pressure operation will be possible within ambient operating temperature between 5~40°C.

PCX-255

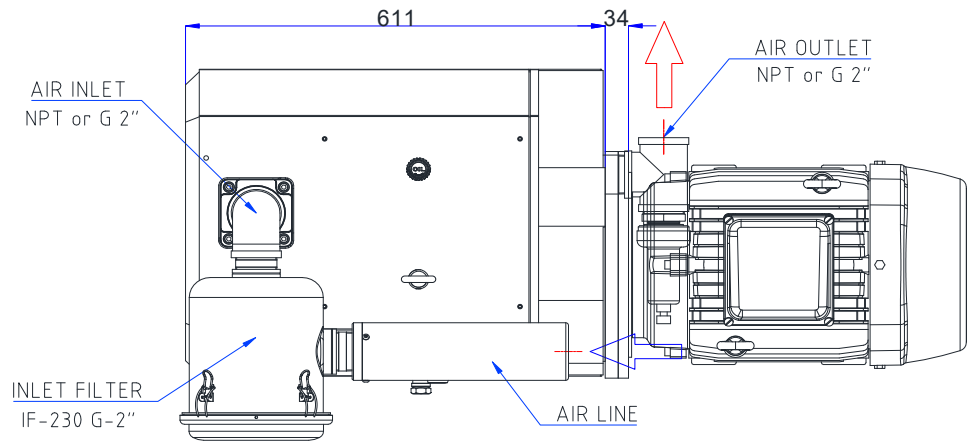

	"A"	"B"
50Hz, 7.5Kw	961mm	-
60Hz, 9.2Kw	1,001mm	-
50Hz, 11Kw	1,171mm	379mm
60Hz, 15Kw	1,171mm	379mm
60Hz, 15Hp	1,139mm	389mm
60Hz, 20Hp	1,183mm	433mm
60Hz, 25Hp	1,239mm	468mm

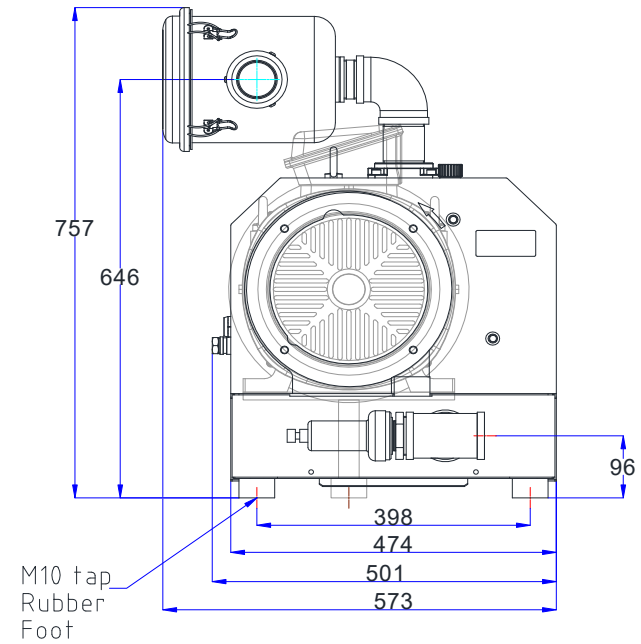
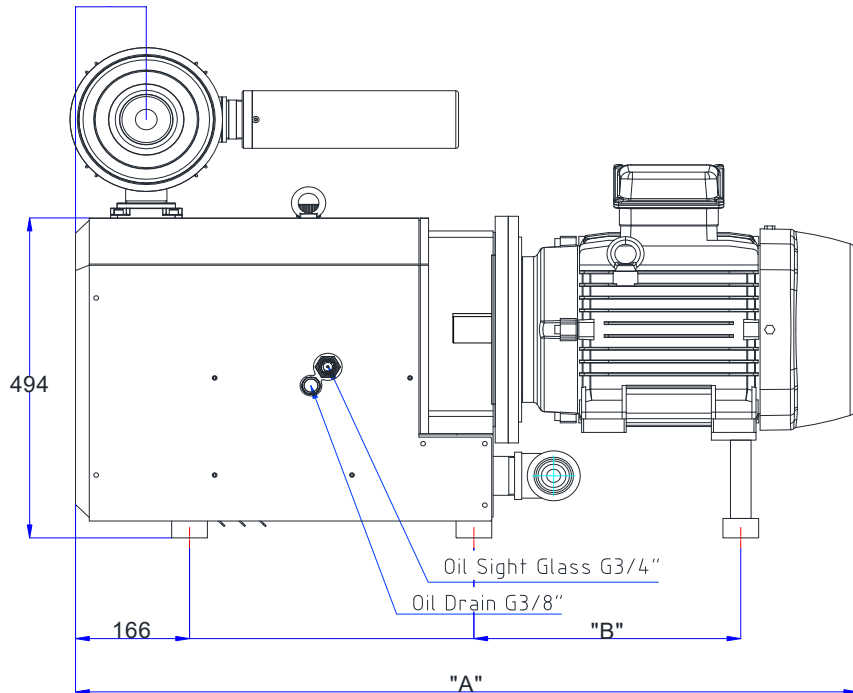

PCX - 305

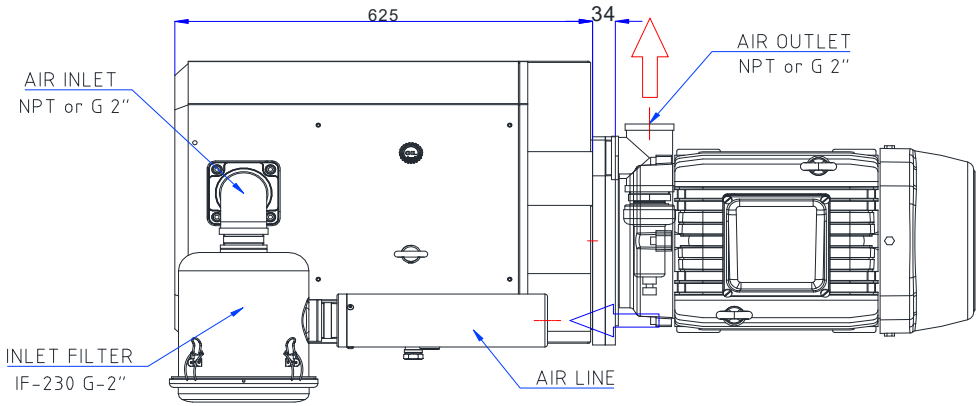

	"A"	"B"
50Hz, 7.5Kw	973mm	-
50Hz, 11Kw	973mm	379mm
50Hz, 15Kw	973mm	379mm
60Hz, 15Kw	973mm	379mm
60Hz, 18.5Kw	973mm	379mm
60Hz, 20Hp	1,195mm	433mm
60Hz, 25Hp	1,251mm	468mm

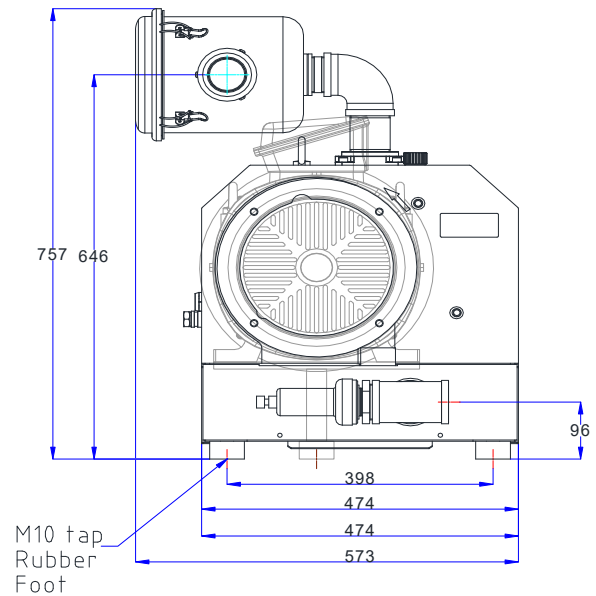
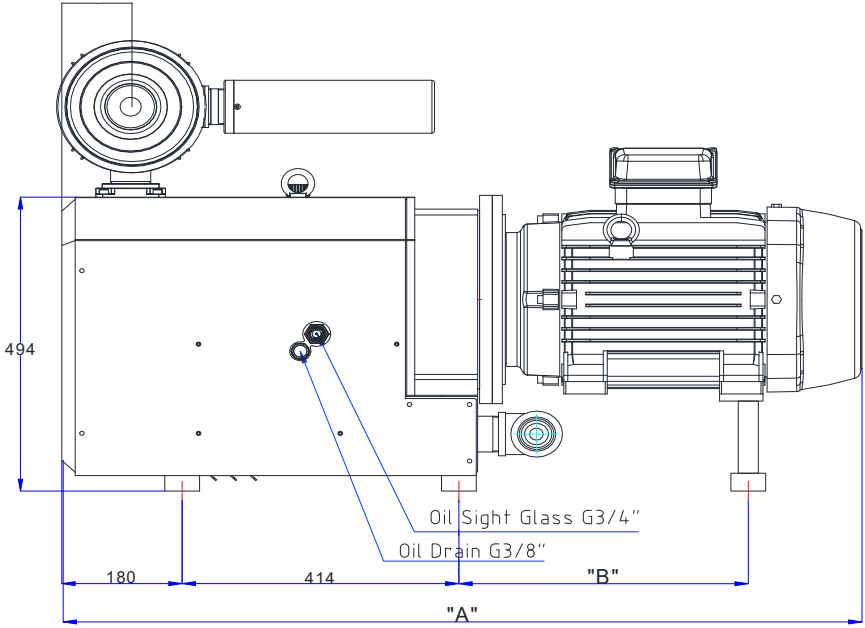

ASS'y DRAWING PCX-255 / 305 (IEC)

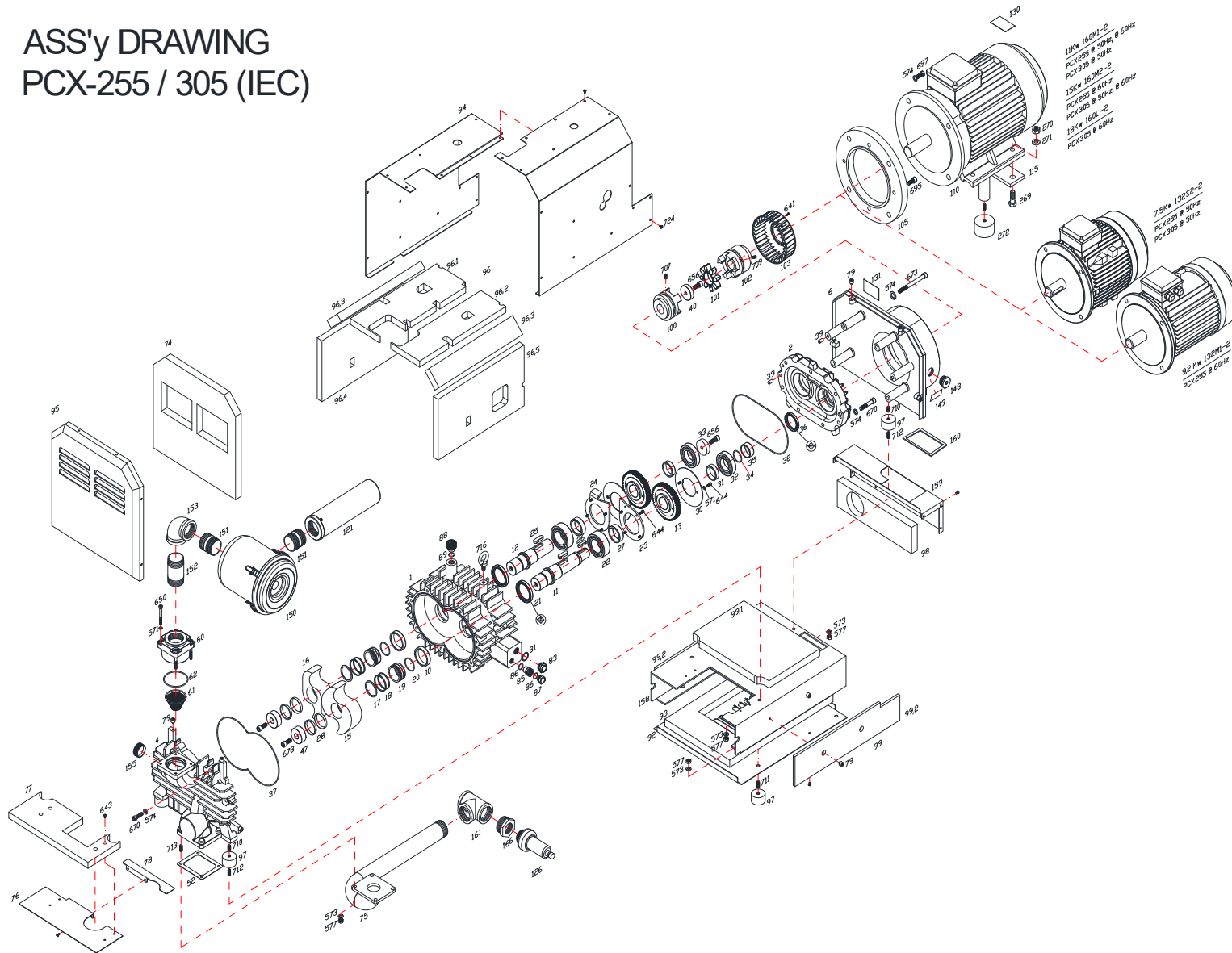

PCX-255/305 PART LIST

Pos. No	Description	Q ty	Pos. No	Description	Q ty	Pos. No	Description	Q ty
1	Gear Box Housing	1	77	Accoustic mat	1	150	Inlet Filter IF-230	1
2	Gear Box Cover (rear)	1	78	Plate (back)	1	151	Pipe, extension, Short, inlet 2"	2
4	Pump Housing Cover 1 (End Plate)	1	79	Support isolator	14 , 12	152	Pipe, extension, inlet 2"	1
6	Fan Housing	1	81	Gasket, Oil Sight Glass	1	153	Elbow, inlet 2"	1
10	Sleeve	2	83	Oil Sight Glass	1	155	plug	1
11	Shaft 1	1	85	Pipe, for Drain Pulg	1	158	Base	1
12	Shaft 2	1	86	O-ring, Drain Plug	2	159	Cover, Exhaust	1
13	Gear	2	87	Drain Plug	1	160	Seal	1
15	Rotor 1	1	88	Oil filler Breather, Plastic	1	161	Tee, Exhaust	1
16	Rotor 2	1	89	O-Ring for Oil filler	1	162	Bushing	1
17	Spacer	2	92	Shield Cover, Bottom	1	163	Pipe, extension, Exhaust	1
18	Piston Ring	4	93	Accoustic Mat for Shield Cover, Bottom	1	166	Bushing	1
19	Sleeve	2	94	Shield Cover, Side (set)	1	269	Bolt	2
20	O-Ring	2	94.1	Shield Cover, Side (left)	1	270	Hexagon Nut	2
21	Shaft Seal,	2	94.2	Shield Cover, Side (right)	1	271	Washer, Spring Lock	2
22	Bearing,	2	95	Shield Cover, Front	1	272	Foot, Rubber for Motor	2
23	Bearing cover (Plate)	1	96	Accoustic Mat for shield Cover, Side (set)	1	571	Washer, Spring Lock	8
24	Bearing cover	1	96.1	Accoustic Mat for shield Cover, Side (left)	1	573	Washer, Spring Lock	11
25	Key, for Gear	2	96.2	Accoustic Mat for shield Cover, Side (right)	1	574	Washer, Spring Lock	22
26	Key, for Coupling	1	96.3	Accoustic Mat for shield Cover, Side (middle)	2	577	Hexagon Nut	11
27	Sleeve	2	96.4	Accoustic Mat for shield Cover, Side (under left)	1	641	Hex. Socket Head Cap Screw	5
28	Power Lock	4	96.5	Accoustic Mat for shield Cover, Side (under right)	1	643	Hex. Socket Head Cap Screw	4
30	Flinger	2	97	Foot, Rubber	7	644	Hex. Socket Head Cap Screw	12
31	Sleeve	2	98	Accoustic Mat for Exhaust cover	1	650	Hex. Socket Head Cap Screw	4
32	Bearing,	2	99	Accoustic Mat for base (set)	1	656	Hex. Socket Head Cap Screw	2
33	Locking Disk	1	99.1	Accoustic Mat for base (on the base)	1	670	Hex. Socket Head Cap Screw	14
34	O-Ring	1	99.2	Accoustic Mat for base (side)	2	673	Hex. Socket Head Cap Screw	4
35	Sleeve	1	99.2	Accoustic Mat for base (side)	2	678	Hex. Socket Head Cap Screw	2
36	Shaft Seal,	1	100	Coupling, Pump Side	1	695	Hexagon Bolt	4
37	O-Ring, Compressor cover,	1	101	Insert, Coupling	1	697	Hexagon Bolt	4
38	O-Ring, Gear Box cover,	1	102	Coupling, Motor Side	1	707	Set Screw	2
39	Dowel Pin	4	103	Fan, new, Plastic	1	709	Set Screw	2
40	Locking Disk	1	105	Flange Adapter for IEC	1	710	Hex. Socket Head Cap Screw	3
47	Locking Disk, side Rotor	2	105	Flange Adapter for NEMA	1	711	Set Screw	4
52	Gasket, Exhaust Silencer, Steel Silencer	1	110	Motor	1	712	Set Screw	3
60	Inlet flange, Upper Housing, G 2"	1	115	Base W/Bolt, Nut for Motor	1	713	Hex. Socket Head Cap Screw	4
61	Inlet screen (Conical)	1	121	Silencer, Inlet	1	716	Eye Bolt	1
62	O-Ring, Inlet Flange, upper part	1	123	Pipe, extension, Exhaust 2"	1	724	Botton Flange Bolt	49
74	Accoustic mat for PCX front cover	1	126	Pressure Regulator	1	102+103	Coupling, Motor Side + FAN SET	1
75	Bracket with Tee	1	130	Label, Direction Arrow	1	95.A	Shield Cover, Front	
76	Plate (front)	1	131	Name Plate	1			

PCX - 405 Dimensions

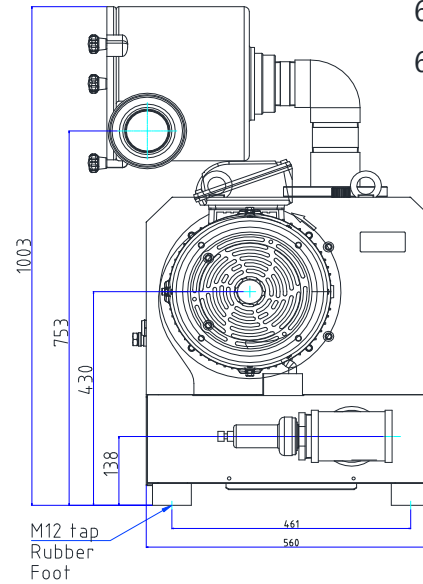
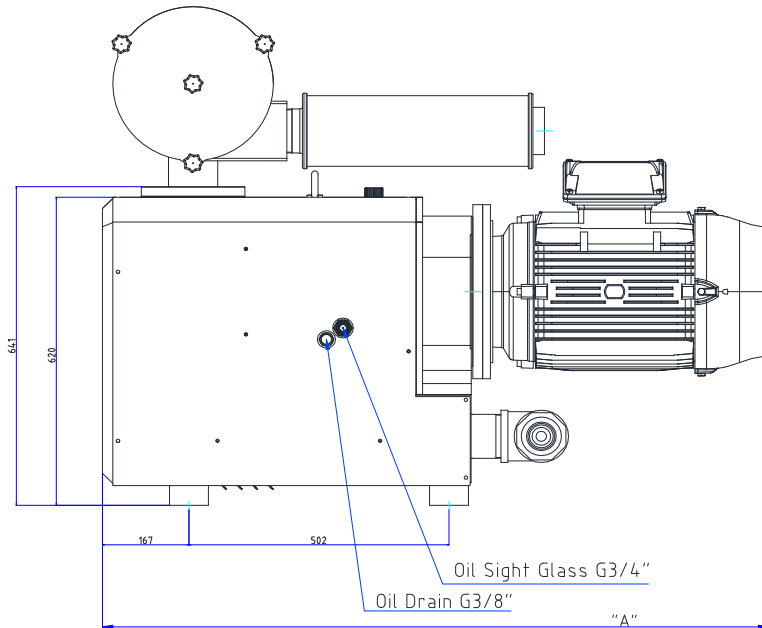
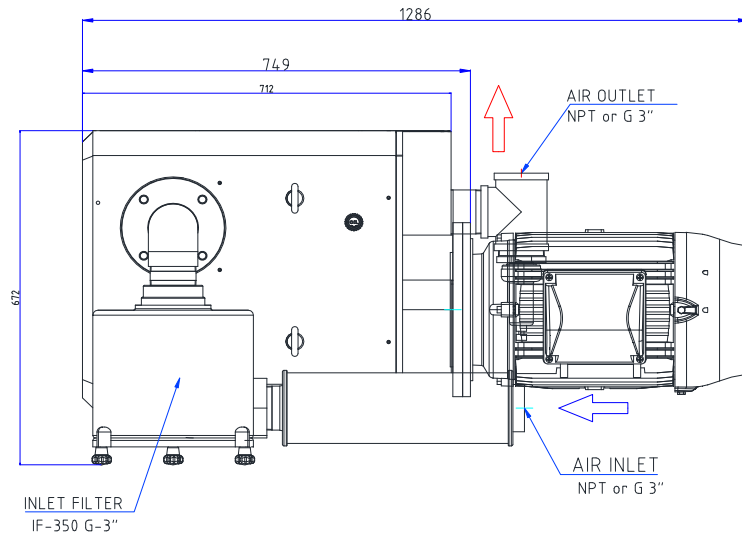

	"A"	"B"
50Hz, 11Kw	1,274mm	-
50Hz, 15Kw	1,274mm	-
60Hz, 15Kw	1,274mm	-
50Hz, 18.5Kw	1,274mm	-
60Hz, 18.5Kw	1,274mm	-
50Hz, 22Kw	1,340mm	346mm
60Hz, 22Kw	1,340mm	346mm
60Hz, 30Kw	1,395mm	514mm
60Hz, 20Hp	1,286mm	-
60Hz, 25Hp	1,287mm	438mm
60Hz, 30Hp	1,381mm	510mm
60Hz, 40Hp	1,391mm	494mm

PCX - 515 Dimensions

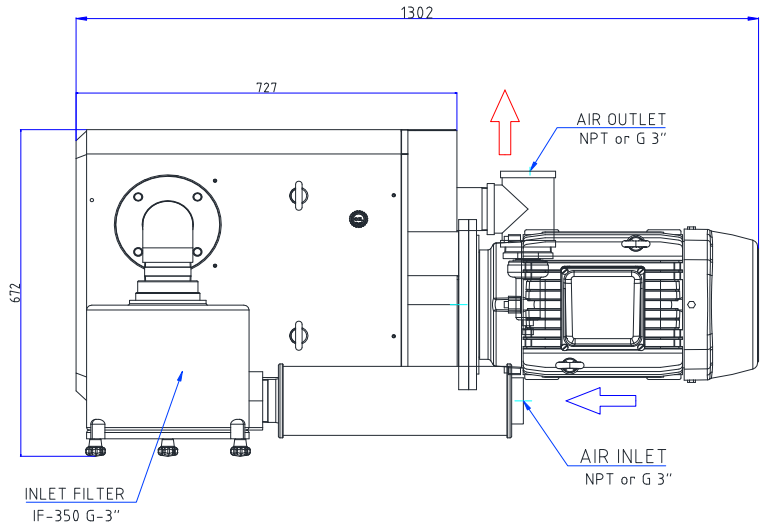

	"A"	"B"
50Hz, 15Kw	1,289mm	-
50Hz, 18.5Kw	1,289mm	-
60Hz, 18.5Kw	1,289mm	-
50Hz, 22Kw	1,355mm	346mm
50Hz, 30Kw	1,410mm	514mm
60Hz, 30Kw	1,410mm	514mm
60Hz, 37Kw	1,410mm	514mm
60Hz, 25Hp	1,302mm	-
60Hz, 40Hp	1,406mm	494mm
60Hz, 50Hp	1,444mm	532mm

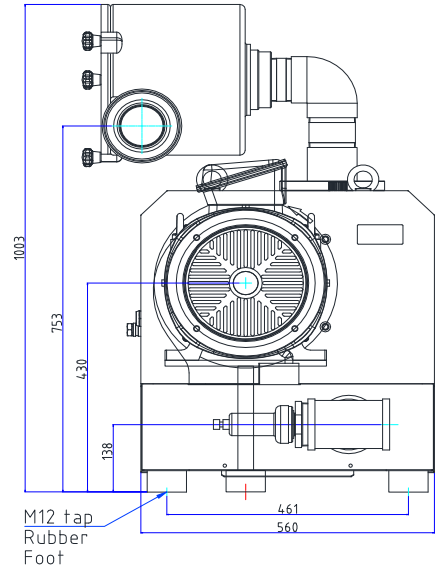
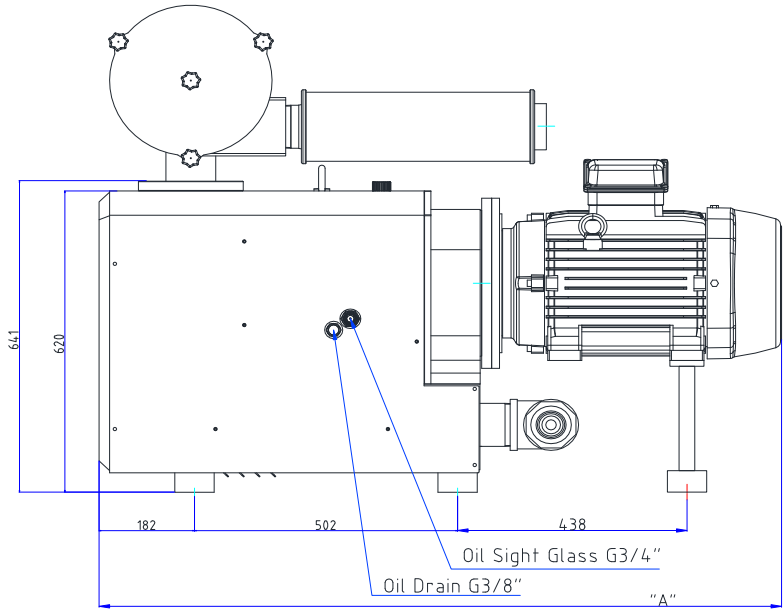

ASS'y DRAWING PCX-405 / 515 (IEC)

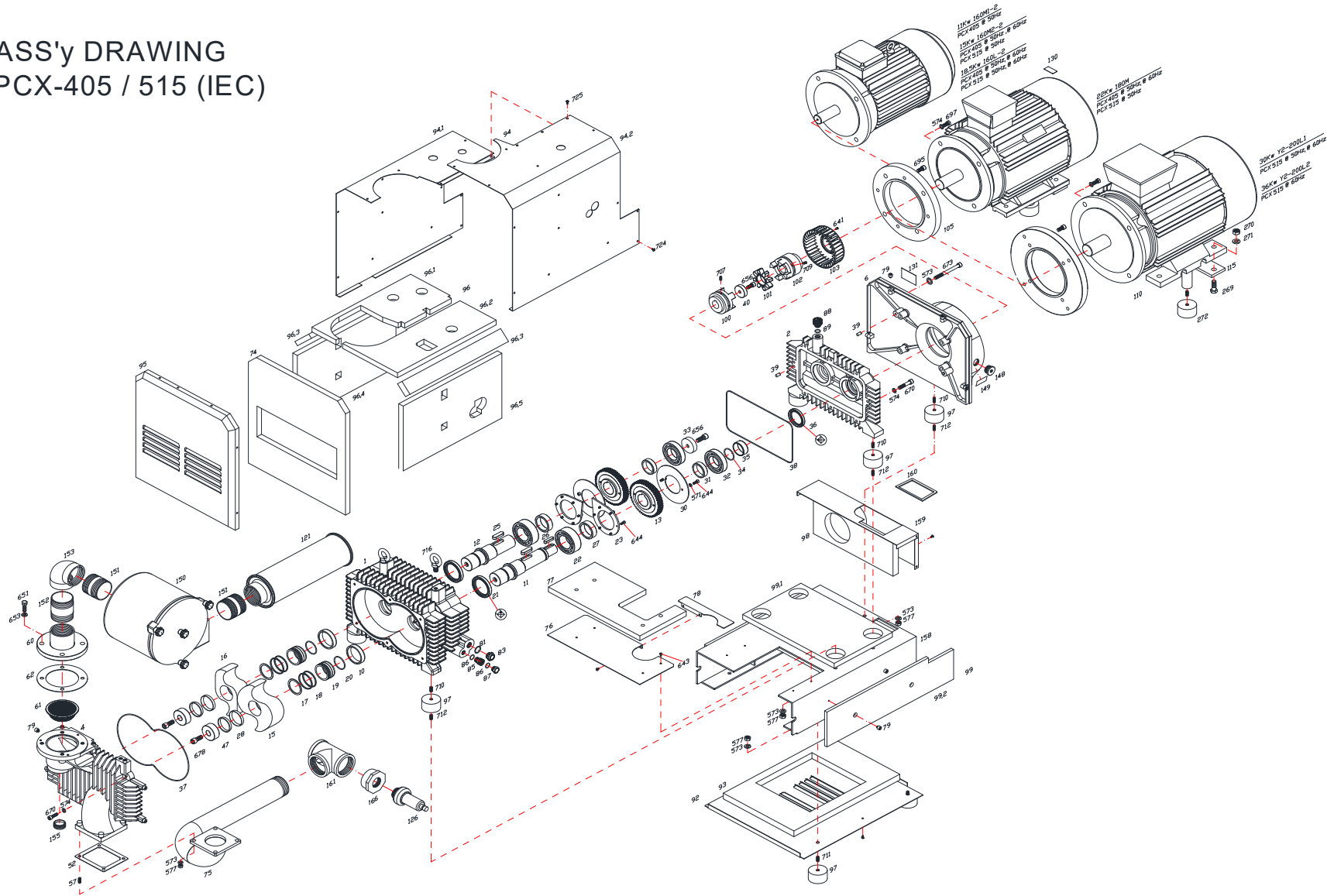

ASS'y DRAWING
PCX-405 / 515 (NEMA)

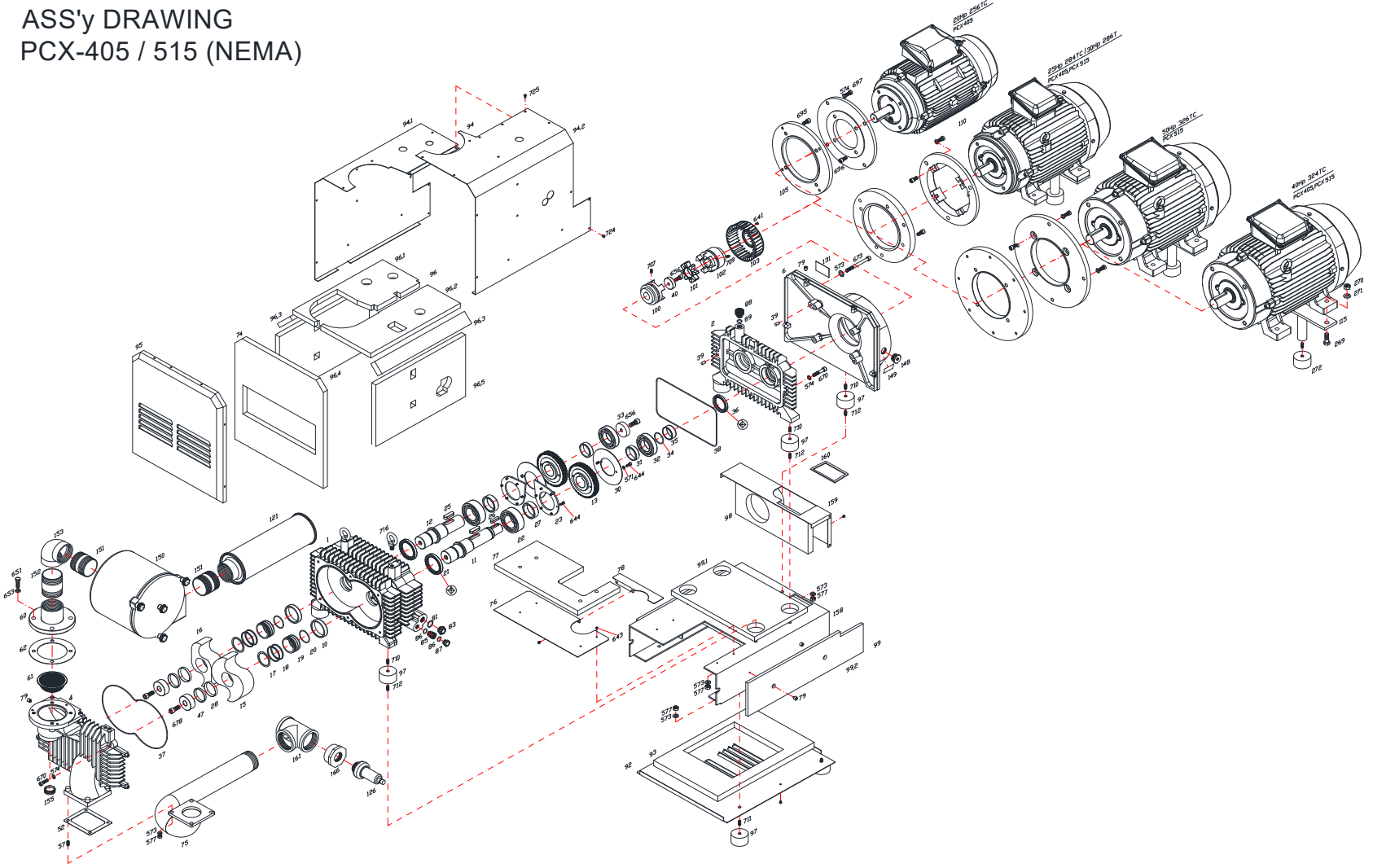

PCX-405/515 PART LIST

1	Description	Q ty	Pos. No	Description	Q ty	Pos. No	Description	Q ty
1	Gear Box Housing	1	77	Acoustic mat	1	151	Pipe, extension, Short, inlet 2"	2
2	Gear Box Cover (rear)	1	78	Plate (back)	1	152	Pipe, extension, inlet 2"	1
4	Pump Housing Cover (End Plate)	1	79	Support isolator	15	153	Elbow, inlet 2"	1
6	Fan Housing	1	81	Gasket, Oil Sight Glass	1	155	plug	1
10	Sleeve	2	83	Oil Sight Glass	1	158	Base	1
11	Shaft 1	1	85	Pipe, for Drain Pulg	1	159	Cover, Exhaust	1
12	Shaft 2	1	86	O-ring, Drain Plug	2	160	Seal	1
13	Gear	2	87	Drain Plug	1	161	Tee, Exhaust	1
15	Rotor 1	1	88	Oil filler Breather, Plastic	1	162	Bushing	1
16	Rotor 2	1	89	O-Ring for Oil filler	1	163	Pipe, extension, Exhaust	1
17	Spacer	2	92	Shield Cover, Bottom	1	166	Bushing	
18	Piston Ring	4	93	Accoustic Mat for Shield Cover, Bottom	1	269	Bolt	2
19	Sleeve	2	94	Shield Cover, Side (set)	1	270	Hexagon Nut	2
20	O-Ring	2	94.1	Shield Cover, Side (left)	1	271	Washer, Spring Lock	2
21	Shaft Seal	2	94.2	Shield Cover, Side (right)	1	272	Foot, Rubber for Motor	1
22	Bearing,	2	95	Shield Cover, Front	1	571	Washer, Spring Lock	16
23	Bearing cover	2	96	Accoustic Mat for shield Cover, Side (set)	1	573	Washer, Spring Lock	17
25	Key, for Gear	2	96.1	Accoustic Mat for shield Cover, Side (left)	1	574	Washer, Spring Lock	14
26	Key, for Coupling	1	96.2	Accoustic Mat for shield Cover, Side (right)	1	577	Hexagon Nut	13
27	Sleeve	2	96.3	Accoustic Mat for shield Cover, Side (middle)	2	641	Hex. Socket Head Cap Screw	5
28	Power Lock (VCX-515)	2	96.4	Accoustic Mat for shield Cover, Side (under left)	1	643	Hex. Socket Head Cap Screw	4
30	Flinger	2	96.5	Accoustic Mat for shield Cover, Side (under right)	1	644	Hex. Socket Head Cap Screw	16
31	Sleeve,	2	97	Foot, Rubber	9	651	Hex. Socket Head Cap Screw	4
32	Bearing	2	98	Accoustic Mat for Exhaust cover (PCX only)	0	653	Washer, Spring Lock	4
33	Locking Disk	1	99	Accoustic Mat for base (set)	1	656	Hex. Socket Head Cap Screw	2
34	O-Ring	1	99.1	Accoustic Mat for base (on the base)	1	670	Hex. Socket Head Cap Screw	14
35	Sleeve,	1	99.2	Accoustic Mat for base (side)	2	673	Hex. Socket Head Cap Screw	4
36	Shaft Seal	1	100	Coupling, Pump Side	1	678	Hex. Socket Head Cap Screw	2
37	O-Ring, Compressor cover,	1	101	Insert, Coupling	1	695	Hexagon Bolt	4
38	O-Ring, Gear Box cover,	1	102	Coupling, Motor Side	1	696	Hexagon Bolt (NEMA only)	4
39	Dowel Pin	4	103	Fan, new, Plastic	1	697	Hexagon Bolt	4
40	Locking Disk	1	105	Flange Adapter for IEC	1	698	Hexagon Bolt	4
47	Locking Disk, Front	2	105	Flange Adapter for NEMA	1	707	Set Screw	2
52	Gasket, Exhaust	1	110	Motor	1	709	Set Screw	2
60	Inlet Flange	1	115	Base W/Bolt, Nut for Motor	1	710	Set Screw	5
61	Inlet screen (Conical)	1	121	Silencer, Inlet	1	711	Set Screw	4
62	Gasket, Inlet Flange	1	126	Pressure Regulator	1	712	Set Screw	5
74	Accoustic mat for PCX front cover	1	130	Label, Direction Arrow	1	716	Eye Bolt	2
75	Bracket with Tee	1	131	Name Plate	1	724	Botton Flange Bolt	41 , 37
76	Plate (front)	1	150	Inlet Filter IF-230	1	102+103	Coupling, Motor Side + FAN SET	1



Registered ISO 9001:2008 / 14001:2004

Acquisition of Certification



WONVAC
WONCHANG VACUUM
WONCHANG VACUUM